

Trade School Newsletter

ADVANCING THE TECHNICAL KNOWLEDGE OF MAINTENANCE TRADESMEN AND PLANT OPERATORS

September 2019

CONTENTS

Volume 1 Edition 10 topics

- **HEATING LIQUIDS BY STEAM SPARGING**
- **SEPARATION & SEGREGATION OF DANGEROUS GOODS**

Regular features

- **The CMMS User**
Job descriptions tell tradesmen what to do.
- **Process control talk**
Differential Pressure Transmitters.
- **From the mechanical workshop**
Experiences with Magdrive Pumps.

The CMMS User

Job descriptions tell tradesmen what to do.

The first words the tradesman reads when he picks up a work order is the job description. The job description must tell him enough information so he can understand what to do.

It is the responsibility of the person writing the work order to be exact and complete in the description of the work they want done. Only by providing sufficient and right information can the tradesman properly ready himself.

A planner's roll is to vet the work and prepare the information and materials needed to perform the job. The planner will go to the job and see the work requester to find out the job details and then rewrite or add information to the job description to make it clear what the tradesman must do.

When there is no planner to do the preparatory work it falls to the leading hand, if he has the time, or the tradesman to find out the details of the work. In an unplanned situation the tradesman will go to the job without knowing what he will encounter. Most times he will not have the right tools and will not know what parts he may need nor perhaps even understand the problem. This approach is slow and wasteful.

The job description provides the opportunity to specify the details needed for the repair. The description does not replace the skills of the tradesman but tells him the problem; the effect of the problem; what needs to be repaired; an overview of how to go about the repair and the location of spare parts if needed.

Here's an example – "The Mixing Tank Agitator Gearbox is making groaning noises when the tank is full. Without the agitator the product sinks to the bottom and sets. Take off the gearbox lid and check for signs of damaged bearings or gears. Take samples of oil from the bottom of the gearbox with the vacuum bottle and check for metal particles. If gear damage is found replace the entire gearbox with the spare in the store and return the damaged unit for overhaul. If no gear damage is evident bring the gearbox back to the

workshop and replace all bearings. A full set of bearings has been reserved in the store. Ensure the oil is to the level mark mid way up the window. Use Mobil DTE 18." With this description a tradesman know what to expect. He still uses all his trade skills to fix the gearbox but now he is focused on the repair and not on preparing for the repair.

*CMMS –Computerised Maintenance Management System

Process control talk

DIFFERENTIAL PRESSURE TRANSMITTERS

The differential pressure transmitter (PT) is used to detect a head of pressure. The sensing element is connected to the process by pipe work and flexes in proportion to the pressure. The resulting distortion produces an electric signal that is amplified and converted to a value on a read-out.

A typical sensing element is a strain gauge of piezoelectric crystal (such as quartz, which produces a voltage across its opposite faces when under mechanical stress) that produces an electric signal proportionate to the pressure. The process side of the sensor sees the pressure to be measured while the other side is connected to a reference pressure. The reference pressure can be full vacuum, atmospheric pressure or another process pressure.

The PT can be used to calculate the flow rate through a pipe. By connecting it across an orifice plate in a pipeline the pressure difference across the orifice can be put into a formula and the flow calculated.

Pressure measurement accuracy ranges from +/- 0.2% to +/- 1% depending on the manufacturer's design. Figure 1 shows a simplified cross-section of a style of pressure transmitter.

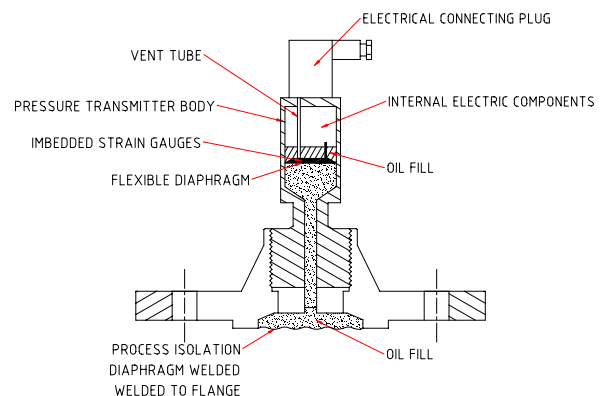

Figure 1 A style of pressure transmitter on a process seal.

Keep a large pressure difference across the PT. When only a small difference between pressures exist on either side of the transmitter it is possible for the error in the transmitter to make it appear there is sufficient pressure when in fact the pressure difference is reversed.

Many process chemicals will destroy the internals of a PT. To prevent contact with such chemicals a flexible diaphragm process seal is used to connect to the process and the PT is mounted on the other side. Select diaphragm materials that

give many years of corrosion free service. Protect against pitting and stress corrosion cracking in particular.

Differential PT's may not be temperature compensating. As the outside temperature changes the oil fill expands or contracts. The change in volume causes the pressure inside the transmitter to also change. This makes the sensor distort and give a false pressure reading. In such cases protect the transmitter from temperature fluctuations.

Diaphragm cleanliness

The sensing diaphragm on which the liquid pressure acts must be kept clean. Sediment build-up will stop the diaphragm from flexing freely and will produce false readings. Products that crystallise at cooler temperatures need special attention. Keep the liquid temperature at the diaphragm surface hot enough to prevent crystals forming in the cooler crevice between the diaphragm and transmitter body or insulate the body to reduce the heat loss through the walls.

HEATING LIQUIDS BY STEAM SPARGING

Steam is often used for heating liquids. Heat is provided to a liquid either through a heat exchanger or by direct injection of raw steam. The injection of steam directly into the process is known as steam sparging.

PROPERTIES OF STEAM

As water is heated in a vessel it boils and some turns into a vapour called 'wet' steam. If heated further the water is all boiled away and at that point the vapour it is called saturated vapour. If the vapour is heated still more it becomes super heated steam. In super heated steam the water molecules are at very high energy levels.

Pressure also affects the amount of energy in steam. Water at sea level boils at 100 °C (212 °F) while on top of Mount Everest it boils at a lower temperature, and in a pressure cooker heated on a stove it boils at a higher temperature. A higher pressure permits higher temperature and energy.

If water is to be used to make steam at more than 100 °C on planet Earth it is done in a pressure vessel called a boiler.

At a given pressure steam takes up a specific volume per kilogram. The lower the pressure the larger the volume needed for the same amount of steam. One kilogram of saturated steam at sea level atmospheric conditions will be at 100 °C, 1 atmosphere pressure and require 1.7 cubic meters volume. The same kilogram at six times atmospheric pressure will be at 158 °C and squeezed to a volume of 0.3 cubic meters. At 100 times atmospheric pressure it will be at 311 °C and squeezed into a 0.018 cubic meter space.

If steam at 100 times atmospheric pressure were released at sea level it would expand instantly 95 times and lose 211 °C in temperature. You would see and hear a massive plume of vapour streaming out of the hole at very high velocities. The excess heat is radiated into the air around the plume.

HEATING LIQUIDS WITH DIRECT STEAM INJECTION

Injecting steam directly into a liquid puts the molecules of high-energy steam in direct contact with the liquid molecules. The energy is transferred from the hotter to the colder molecules and so the process liquid warms-up. As more steam is injected the liquid's temperature rises toward the steam's temperature.

The temperature rise one kilogram of steam can cause to one kilogram of liquid depends on the ability of the liquid to take in the energy. This ability to absorb energy is known as the liquid's specific energy. It is the energy needed to raise the temperature of one kilogram of the liquid by one degree centigrade. If we can find out how much specific energy is needed to heat one kilogram of a liquid one degree we can calculate how much steam, at a certain temperature and pressure, is needed to heat the liquid.

The time taken to heat the liquid depends on how fast the steam is introduced, how much hotter the steam is than the liquid and how well it is distributed through the liquid. If 1000 kilograms of liquid is to be heated 100 °C higher but only one kilogram of steam per hour could be supplied it will take an eternity to warm. Similarly if the steam was only 101 °C hotter than the liquid there would be an initial surge in the liquid temperature as it warmed but the final few degrees rise would take longer and longer. And unless the steam is evenly distributed in the liquid there would be pockets of hot liquid around the sparge, with the liquid further away getting progressively colder.

When heating liquids with a sparge insure there is a plentiful supply of steam at sufficiently high temperature and the steam and process liquid are well mixed together. Examples of some typical steam spargers are shown in Figure 1.

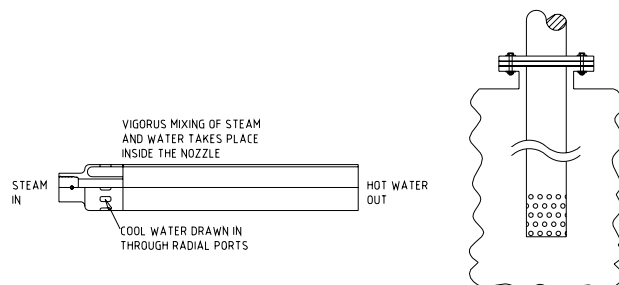

FIGURE 1 Two typical steam sparge designs

How fast the steam can be injected into the liquid depends on the steam pressure and the size of the hole through which the steam is squirted. With the specific energy of the process liquid and steam known it is only necessary to decide how quickly to heat up the liquid and then the size of the hole to provide the steam can be calculated.

Once the injection hole area is known, the size of the pipe work to supply the steam from the boiler can be determined. Usually a control valve responding to a temperature sensor in the process liquid is installed in the steam supply line. As the process temperature rises toward the required or 'set' temperature the control valve regulates the rate of steam supply and the speed of temperature rise. Figure 2 shows a steam sparging circuit for a boiler feed water tank.

5	Oxidisers	Release oxygen and may combust.
6	Poisonous	Cause death or injury to life if it enters into the body.
7	Radioactive	Emit radiation.
8	Corrosive	Cause damage to human tissue by chemical reaction.
9	Miscellaneous	Hazardous materials not fitting into one of the previous categories.

TABLE 1 Classes of Dangerous Goods

Some of the categories are further broken down into sub-classes that better define the risks associated with the materials. For example gases are sub-classified as flammable (Class 2.1), non-flammable and non-toxic (Class 2.2) and poisonous (Class 2.3).

Dangerous goods can also have multiple classifications. Once the primary classification is determined additional classifications are known as subsidiary risks. For example liquid air is classed as 2.2 (non-toxic gas) with a sub-class of 5.1 (oxidising agent).

Because many dangerous goods are transported internationally the United Nations have established an internationally accepted numbering system to indicate dangerous goods. The UN Number must appear on all transport documentation.

To assist with emergency situations involving dangerous goods a special coding system known as the Hazchem Code has been developed. The code's alphanumeric characters inform the emergency services of the immediate response actions needed to minimise hazards and restrict the spillage.

All this relevant information and a telephone number for emergency contact is displayed on the Hazchem Sign or label that accompanies transportation of the chemical. An



example of a Hazchem sign is shown in Figure 1.

Figure 1 Sulphuric acid HAZCHEM sign

SAFE STORAGE PRACTICES

A good philosophy to adopt when storing dangerous good is to only store the least quantity necessary for a short period of time and make arrangements to replenish stocks often. An alternate approach is to store the required quantity in several small containers. If one were to be spilt or ruptured only a small volume would be involved.

In situations where large amounts or multiple dangerous goods are required at a site the strategy of separation and segregation combined with containment is adopted.

Separation is the purposeful creation of a barrier between incompatible substances so they can never come together. Segregation is the spacing of incompatible substances from

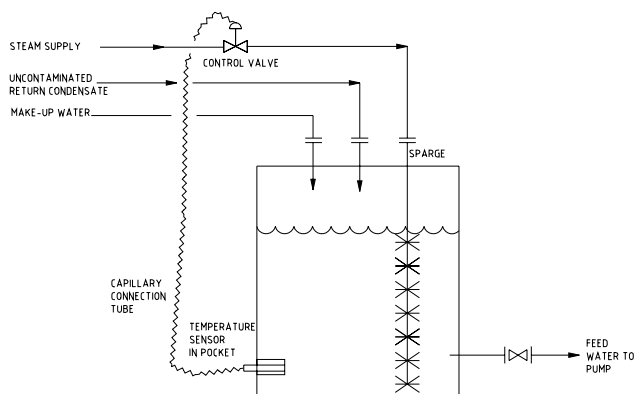

FIGURE 2 Steam sparging a boiler feed water tank

CONNECTING SPARGES TO THE EQUIPMENT

Steam sparging can generate a great amount of vibration. Especially if there is a big pressure difference between the steam pressure and the process pressure. When pressure drops steam expands. In order for steam to flow through the pipe to the outlet at the same rate it is turning from high pressure to low pressure steam it speeds up. The increase in velocity causes vibration and if sufficiently fast it will gradually wear away the sides of the exit hole(s).

Sparges welded into vessels need large, thick compensating plates to spread the vibration over a larger area of weld. If the weld area is small it cracks from work hardening caused by the vibrating sparge. This is important on stainless steel vessels as stainless has little resistance to work hardening.

Sparge lances put directly into the liquid require many holes below the liquid surface to quickly vent off the steam. Make enough 4 to 6 mm holes in the sparge so the sum of their areas is at least equal to one and a half times the area of the steam supply pipe.

Mike Sondalini - Maintenance Engineer

SEPARATION & SEGREGATION OF DANGEROUS GOODS

Many of the chemicals we deal with each day are dangerous and need to be handled correctly and safely. Safe use of dangerous goods includes recognising when situations can arise where the consequence of a failure or error will result in danger to life, property or the environment. One of the methods used to minimise risk when dealing with dangerous goods is by separation and segregation.

DANGEROUS GOODS

A dangerous good is any gas, liquid or solid that has been classified and is listed in the Australian Code for the Transport of Dangerous Goods or other international equivalent Codes. Typically they are chemicals that destroy or have the potential to destroy life, property or the environment. They are classified and labeled as a dangerous good belonging to one of the categories shown in Table 1.

CLASS	CATEGORY	DESCRIPTION
1	Explosives	Fragment violently.
2	Gases	Are vapour or gas at atmospheric conditions.
3	Flammable liquids	Liquids able to be ignited and burn.
4	Flammable solids	Spontaneously combust or liberate flammable gases in contact with water.

each other within the same location. Containment is the deliberate restriction of a hazard to a small geographic area.

The Material Safety Data Sheet (MSDS), which suppliers of chemicals must provide to all users, indicates the requirements for proper storage of the chemical. In addition various Codes, Standards and Regulations are available that specify separation and segregation requirements.

Usually separation is achieved by installing walls of suitable material between incompatible or hazardous chemicals. A typical example is the bunding around acid storage tanks. Another example is the locked drug and poisons cabinet in a doctor's surgery.

Segregation is achieved by spacing incompatible chemicals a prescribed distance apart and preventing mixing of any spillage. An example is the storage shelves in a hardware store where packages of incompatible chemicals are separated onto individual shelves.

Containment is achieved by limiting any spillage or discharge to the boundaries of an enclosure. An example is the concrete floor in a mechanic's workshop graded towards a drain so oil spills can be captured. Another example is the bunding around aboveground fuel tanks that limit spills and leaks to the immediate area of the tank.

PLAN TO CONTROL THE HAZARDS

In all cases where chemicals have associated risks and hazards there must be a plan in place to control the hazards. The best plans are those put together by the people that have to use a chemical and the people who supply the chemical. This permits practical solutions to be used that satisfy the dangerous characteristics of the chemical.

The plan must satisfy the hazards that arise from the most severe of occurrences. If when designing a plan it is evident that a major catastrophe is beyond control then it is necessary to redesign the facility and reduce the risk to one that is manageable with available resources and technology.

Plans must consider, amongst the site specific issues, materials of construction; washing down facilities for contaminated items and clothing; protection against heat and ignition sources; storage of emergency response equipment; fire protection requirements; the procedure to handle spillage and the procedure to handle major emergencies.

An additional important requirement is practice. Where your plan includes using in-house resources to confront a hazard the resources must be at constant readiness. This means regular practice in confronting the hazard. If a hazard does occur you want to be ready and prepared to confront it rather than hoping things will be all right.

Mike Sondalini – Maintenance Engineer.

From the mechanical workshop

Experiences with magnetic drive pumps.

ABSTRACT

Experiences with magnetic (magdrive) pumps. Magnetic drive pumps come in three varieties – canned motor pumps, all metal pumps and plastic lined metal pumps. They are sealless and cannot leak into the environment. Long, repair-free service life depends on recognising the limitations of

these pumps. This article covers issues with using direct mounted, lined magdrive pumps experienced 'in the field'.

Keyword: separation liners, chemical compatibility, sediment, particulate.

The smaller magdrive pumps sizes come with motors direct mounted to the pump and there are no shaft alignment problems. The internal bearings and shaft in the plastic lined pumps are usually corrosion-free hard silicon carbide. The process liquid lubricates the bearing surfaces. Canned motor pumps have dual containment.

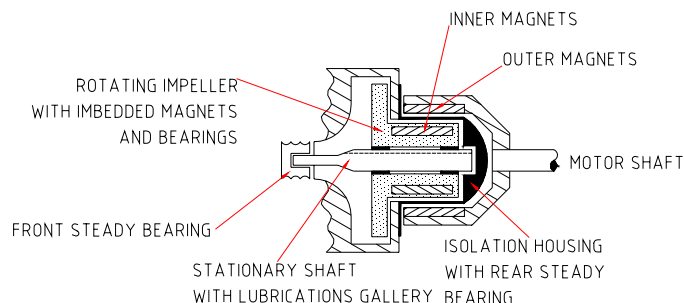

Figure No. 1 Simplified cross-section of a magdrive pump.

They operate by using magnetic attraction and repulsion to turn the impeller. Within the pump is a set of high strength permanent magnets imbedded around the outside of a hub projecting from the back of the impeller. A thin liner or shroud with a small (2 - 4 mm) clearance to the hub seals the pump internals. At a similar distance on the outside of the liner is another set of magnets connected to the motor. As the motor turns the outside magnets drive the inside magnets.

Here are some problems that can arise with magdrive pumps.

- They cannot be run dry for more than a few seconds. When the bearings loose lubrication heat is quickly generated and conducted through the bearings. Plastic impellers can distort. Install no flow detection, like a flow switch or under-current detection, to protect the pump.
- A high amount of heat can be generated by the coupling action of the magnets. This is worst in the canned motor and metallic pumps. The heat warms the liquid in the pump and is passed into the process. In a refrigeration system the excess heat may exceed the design loads for the system.
- The pumps do not tolerate particulate and sediment in the pumped fluid. Because the process fluid lubricates the bearings, entrained sediment can block galleys and ports supplying lubrication. Only use them on clean fluids.
- Sediment will also work its way into the thin cavity between the outside of the impeller hub and the inside of the separation liner. The sediment is dragged around by the impeller hub and scours the liner. If allowed to continue the sediment gouges through the separation shroud and the pump leaks.
- Sediment settling on the bottom of tanks may come loose and be drawn through the pump. Set pump suction nozzles well off the tank floor.
- The heat generated by the action of the magnets may be high enough to bake constituents of the process liquid onto the impeller magnet hub and a build-up develops.

- Processes involving liquids that crystallise at room temperatures, or higher, require the pump to be trace heated to prevent crystals forming in internal cavities.
- Internal plastic liners of magdrive pumps are susceptible to damage if hard foreign objects are drawn through the pump. Install a suction strainer if the process can contain large foreign materials like wood and rock. Large solids can also block impeller passages.
- Separation liners made of non-conducting materials such as fiberglass and plastic composites cannot handle high pressure. If the pump experiences hydrostatic pressure from thermal expansion of liquid trapped between valves, or pressure hammers from fast closing valves, it is likely the separation liner will crack or rupture. Relieve thermal pressure build-up if closed valves can isolate the pump.
- Ferrous particles, such as rust or steel filings, will be attracted to the magnets. It is a particular problem when bulk solids containing traces of ferrous metal are dissolved in a tank or where tank bottoms are being cleaned out. In-line magnets on the pump suction can help reduce the problem, or the tank contents can be let to settle and then the clear liquid above pumped out. The contaminated ullage is handled separately by a different style of pump or method.
- Keep fingers away from the back of the impeller when it is reinstalled. The magnetic attraction between the inner and outer magnets cannot be restrained by hand and people have been hospitalised with crushed fingers.
- Under high unexpected flows and pressures the pump is required to deliver more power through the impeller. If the conditions are beyond the capacity of the pump, the magnets de-couple and the drive is lost. To reengage the magnets the pump needs to be stopped and restarted. When selecting a magdrive pump chose one that will handle likely peak conditions.
- In some situations the chemical being pumped has diffused through the plastic lining and attacked the underlying metal. This occurred on a magdrive pump pumping 26% HCl at 80° C. Through a manufacturing error the plastic lining over the impeller magnets was not up to standard and the HCl diffused through to the magnets where it corroded them and caused the inner magnet hub to bulge and rub against the separation shroud. Eventually the impeller jammed and would not turn.
- If you don't need the liner for chemical protection then you can get a cheaper all-metal pump.
- These pumps can be wired-up incorrectly and run backwards. They will seem as if they are pumping but the flows and pressures will be much less than if they were going the right way.